

Description	Specification
External dimensions (height x width)	290 mm x 290 mm
Distance between axis	239 mm x 239 mm
Lenghtways tubes	Extruded alluminium EN AW 6082 T6 - Ø50x3mm
Crossways tubes	Extruded alluminium EN AW 6082 T6 - Ø30x3mm
Connecting plate	Cast alluminium EN AC 42200 T6
Welding process	TIG -141 / ISO 4063
Available lengtht (cm)	10,5 - 21 - 25 - 50 -100 - 150 - 200 - 250 - 300 - 350 - 400
Connection systems	QXFC - QXSM10

Section Area (mm ²)	Moment of inertia Y - axis (mm ⁴)	Moment of inertia Z - axis (mm ⁴)	Selfweight (approx.) (N/m)		
1772	21.924.800	10.000.000	80		

Span [m]	Centre Point Load (C.P.L.)			Third Point Load (T.P.L.)			Quarter Point Load (Q.P.L.)			Fifth Point Load (F.P.L.)			Uniformly Distributed Load (U.D.L.)		
	Point Load [kg]	Full Load [kg]	Central Deflection [mm]	Point Load [kg]	Full Load [kg]	Central Deflection [mm]	Point Load [kg]	Full Load [kg]	Central Deflection [mm]	Point Load [kg]	Full Load [kg]	Central Deflection [mm]	Load [kg/m]	Full Load [kg]	Central Deflection [mm]
1	2867	2867	0,3	1656	3311	0,3	1195	3584	0,3	941	3766	0,3	4679	4679	0,3
2	2015	2015	2	1256	2513	2	953	2858	2	778	3111	2	2289	4578	3
3	1541	1541	5	1004	2007	5	786	2358	6	658	2631	6	1244	3733	7
4	1244	1244	9	832	1664	11	666	1998	12	539	2157	12	748	2993	14
5	1038	1038	15	707	1413	18	575	1724	20	447	1787	20	487	2433	22
6	887	887	23	613	1225	27	484	1451	30	380	1520	30	341	2044	33
7	772	772	32	539	1077	38	416	1247	41	329	1316	41	250	1753	45
8	680	680	43	479	959	51	363	1089	54	290	1159	55	191	1529	59
9	605	605	55	430	859	66	321	964	69	257	1028	70	150	1353	76
10	544	544	69	388	776	83	287	860	85	230	921	87	121	1207	94
11	490	490	85	353	705	102	258	773	104	207	830	106	98	1083	114
12	445	445	103	321	643	123	233	698	124	188	753	127	81	975	136
13	406	406	122	294	588	146	211	633	146	171	684	150	68	882	159
14	370	370	143	270	539	171	193	578	171	156	625	176	57	799	184
15	339	339	166	248	496	199	176	527	197	143	572	202	49	730	212
16	311	311	191	229	458	228	161	482	225	131	524	232	41	664	240
17	285	285	218	211	422	260	147	442	255	121	483	263	36	604	270
18	261	261	247	195	390	294	135	404	286	110	441	295	31	557	305

Load table has been prepared in accordance with UNI ENV 1999-1-1 (Eurocode 9).
 When calculating the allowable loads shown in the table, it is assumed that the trusses are simply supported at the end connection and that static loads will be applied to the node points.
 The application of the load shall be on the centre line of the truss.
 The values shown in the table are the allowable statics loads that can be applied to the truss. This is the live load or the payload.
 The self weight of the truss has been taken into account when calculating the values in the table.
 It should be noted that this are idealised loading condition and the User shall re-analyze the truss for the loading condition which prevail for the application begin considered.

Date of issue 31/07/2008	Litec is a Brand of Staging Systems Europe S.p.A. www.litetruss.com - info@litetruss.com	
-----------------------------	---	--

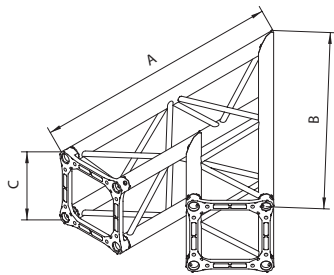

QD30SL2045

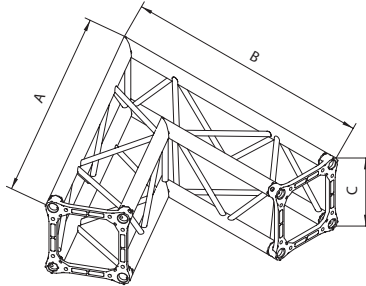

QD30SL2060

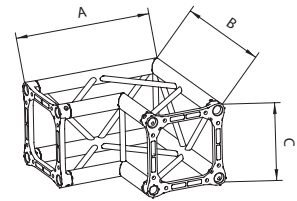

QD30SL2090

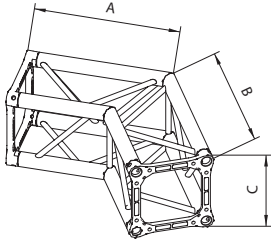

QD30SL2120

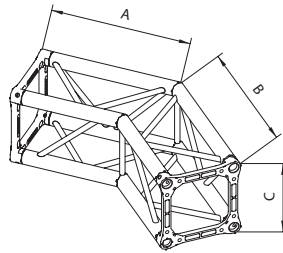

QD30SL2135

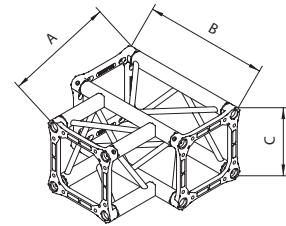

QD30ST3

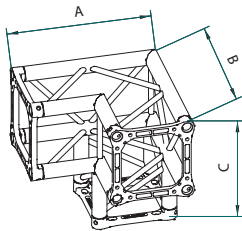

QD30SL3

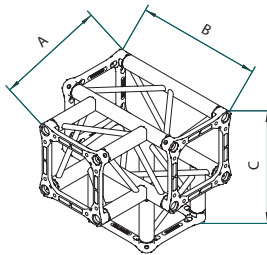

QD30ST4

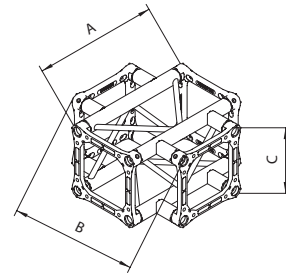

QD30SX4

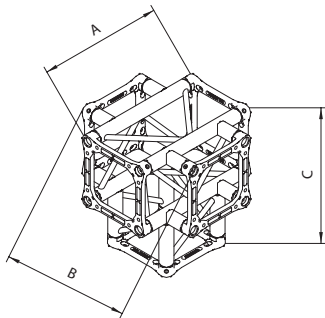

QD30SX5

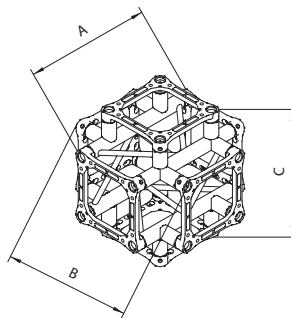

QD30SX6

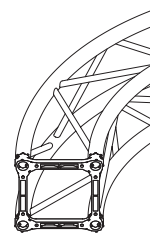

Q = Square truss

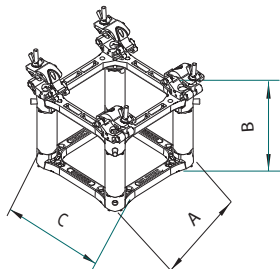

QD30SACL

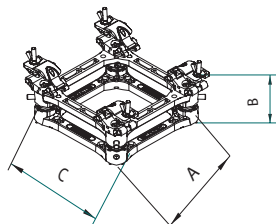

QD30SACS

TRUSS

Code	Dimensions (cm)	Weight (Kg)
QD30S010M5	29x29x10.5	2.90
QD30S021	29x29x21	3.60
QD30S025	29x29x25	3.00
QD30S050	29x29x50	6.40
QD30S100	29x29x100	9.30
QD30S150	29x29x150	12.90
QD30S200	29x29x200	16.30
QD30S250	29x29x250	10.60
QD30S300	29x29x300	23.20
QD30S350	29x29x350	26.40
QD30S400	29x29x400	30.00

CORNERS

Code	Dimensions (cm)	Weight (Kg)
QD30SL2045	100x100x29	12.70
QD30SL2060	100x100x29	14.20
QD30SL2090	50x50x29	8.10
QD30SL2120	50x50x29	9.30
QD30SL2135	50x50x29	9.60
QD30SL3	50x50x50	10.70
QD30ST3	50x50x29	9.40
QD30ST4	50x50x50	12.40
QD30SX4	50x50x29	10.40
QD30SX5	50x50x50	13.50
QD30SX6	50x50x50	15.40
QD30SACL	29x21x29	5.70
QD30SACS	29x10.5x29	5.10

RINGS

Curves, rings and ellipses are available on demand

Minimum diameter 2 m

Diameter measurement external

Weight per meter (aprox.) 8Kg